



KLEIN + HUMMEL GmbH
Zeppelinstrasse 12
73760 Ostfildern/Germany
Phone: +49/ (0)711/458930
Fax: +49/ (0)711/45893-35
<http://www.klein-hummel.de>
eMail: info@klein-hummel.de

KH(SAFE 500)

SOUND SYSTEM FOR EMERGENCY PURPOSES

www.klein-hummel.de

All specifications are subject to change without prior notice

© Copyright 2004 by KLEIN + HUMMEL GmbH

KH(SAFE 500)

Sound System for Emergency Purposes

A Sound System for Emergency Purposes...

... as specified in EN 60849 is a „sound reinforcement and sound distribution system to be used in case of an emergency to induce persons staying in an area inside or outside of a building to evacuate this area quickly and orderly“. Such a system has to give „clear information on measures to be taken for the protection of human life and other tangibles in one or several areas.“

The request for continuous monitoring...

...does not only demand a faultless operation of the system but also requires a continuous control and monitoring system for all relevant signal paths and components which are used for emergency announcements.

According to the EN standard a failure of any component or an interruption of a signal path must be recognized and shown within 100 seconds after its appearance, meaning that critical elements must be surveyed and controlled constantly at all times. This also includes the capsule of the emergency microphones, loudspeaker circuits and the digital message memory.

The new sound system

KH(SAFE 500)

from KLEIN + HUMMEL complies fully with these requirements and meets completely the EN 60849 standard.

Special attention has been paid to the constant uninterrupted monitoring of the complete sound system: All control functions are always active „in the background“. A malfunction will be signalled within less than 100 seconds after its occurrence.

Monitoring is carried out inaudible without interrupting background music or other announcements. The system can even monitor loudspeaker circuits that are switched off.

The KH(SAFE 500) realizes an economic way of building reliable sound systems for emergency purposes in a clear and easy to apply technology .

speaker lines by means of relay boxes (multipin connectors), monitoring for non active lines with PTA 16, digital microphone monitoring DMC1 can be plugged in, 16 inputs /16 outputs 100 V (Phönix plug/screw terminals), power supply 230V AC 50/60 Hz about 30 W, 24 V DC about 1.25 A, 19" rack type housing 2 units (88 mm), depth = 260 mm.

DLC 8 N - digital line control system

Same as DLC 64 N, for only 8 loudspeaker lines, without option of extension

DMC 1 - digital microphone control module

Will be plugged on to DLC 8 N /DLC 64 N, analyzing monitored ASS 503 emergency microphones and complete signal path, power supply from DLC 8 / 64 N, with system connector.

DLR 16 N, DLR 32 N - extension relay boxes

For extension of DLC 64 N base unit for 16 / 32 additional loudspeaker lines, female control connector 25pin Sub-D; with system cables , inputs: 16 / 32, outputs: 16 / 32, 100 V (Phönix plug/screw terminals), power supply from the DLC 64 N base unit via system cable, 19" rack type housing 2 units (88 mm), depth = 260 mm.

AHM 510 - control speaker

100 V input channels: 10, control speaker 2.5 W with transformer, additional output 1.5 W, 1 input select switch, 1 volume control switch, 1 emergency call relay, 1 mute relay, relay power supply 24 V DC, 20 mA each, cassette for 19"-subrack, 3 units, 16 sub divisions (5.08 mm each).

KSM 500 - control and interface module

Functions: management and switching power supply, analyzing and generating the requirements and commands for 4 evacuation announcements and alarm tones, chime control, analyzing and routing error messages of all components, piezo buzzer for acoustic error and warning indication, error group visual indication: 7 LEDs, accumulated fault signalling output, power supply 24 V DC, 100 mA max., cassette for 19"-subrack, 3 units, 16 sub divisions (5.08 mm each).

NM 501 - power supply module

Power supply for all 500 series modules, non interrupted switching to battery powered operation, remote switching of power relays in power amplifiers, 4 control outputs for time staggered switching amplifier power relays, power out: 24 V DC stabilized, 1.25 A, mains: 230 V AC 50/60 Hz, 40 VA, battery in: 24 V DC, 1.5 A max., cassette for 19"-subrack, 3 units, 16 sub divisions (5.08 mm each).

NE 24 T - emergency power manager

Functions: monitoring mains power supply, temperature controlled charging and checking of batteries, 6 controlled and fuse protected 24 V DC outputs for devices, many monitoring and error message functions, power supply 230 V AC 50/60 Hz, 19" rack type housing 2 units. (Manufacturer AVB-Blumberg / www.avb.de),

BGT 540 / BGT 5/2 - subracks

For KH(Safe 500) and all K + H 500 Series modules, 19", 3 units, 84 sub divisions, BGT 540 (depth = 40 mm), BGT 5/2 (depth = 240 mm, suitable for EURO-cards 160 x 100 mm, too)

BLP 504 / BLP 508 / BLP 516 - blank panels

To cover an empty space in a subrack, screws included, finish aluminium natural anodised, BLP 504 (4 sub divisions 5.08 mm each), BLP 508 (8 sub divisions 5.08 mm each), BLP 516 (16 sub divisions 5.08 mm each)



DLC 8N



DLR 16N



DLR 32N



AHM 510



KSM 500



NM 501



DMC 1

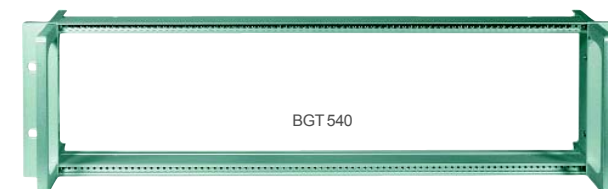

BGT 540



BGT 5/2



BLP 504



BLP 508



BLP 516

KH(SAFE 500)

Technical Specifications

ASS 503 - emergency microphone

Back electret condensor microphone, goose neck 8 x 250 mm, call groups: 3 + all call, lines per group: 16, attention signal preceding announcements: about 0.5 sec., indicators: 2, output: 1.55 V electr. bal., frequency response: 200 Hz...15 kHz \pm 3 dB, connector: RJ 45 8pole/cat.V., power supply 24 V DC, 100 mA max., dimensions: W x H x D = 120 x 43 x 150 mm, interface: snap in box 110 x 70 mm

ESM 504 - input/priority module

Inputs: 4, input sensitivity according to EX/SX plug in prints, output: 1.55 V / 600 Ohms electr. bal., power supply 24 V DC, 200 mA max., cassette for 19"-subrack, 3 units, 16 sub divisions (5.08 mm each)

GAM 503 / A - chime/alarme tone generator module

Alarm tones: 5, several alarm sequences in connection with SPM 5000, input: 1.55 V / 20 kOhm unbal., output: 1.55 V / 600 Ohm electr. bal., power supply 24 DC, 600 mA max., cassette for 19"-subrack, 3 units, 16 sub divisions (5.08 mm each)

SPM 5000 - voice message module

Record / playback: 130 sec. max., sections: 4 max., record input: 2 mV / 1 kOhm, ALC, main input: 1.55 V / 20 kOhms unbal., output: 1.55 V / 600 Ohm electr. bal., frequency response 50 Hz - 7 kHz, quantization: 16 Bit, power supply 24 V DC, 150 mA max., cassette for 19"-subrack, 3 units, 16 sub divisions (5.08 mm each)

TTM 504 - line input module

Input module for 4 unbalanced line sources, with tone control treble/bass, output: 1.55 V / 600 Ohm electr. balanced

GAM 503 / G/A - chime/alarme tone generator module

chime sounds: 5, main input: 1.55 V / 20 kOhms unbal., output: 1.55 V / 600 Ohm electr. bal., power supply 24 V DC, 600 mA max., cassette for 19"-subrack, 3 units, 16 sub divisions (5.08 mm each)

HAV-E - automatic amplifier monitor

Monitored power amplifiers: 6 max., standby amplifier: 1, inputs: 1.55 V, outputs: 1.55 V, power supply: mains 230 V AC, 50/60 Hz, 12 VA, battery: 24 V DC, 300 mA max., 19"- rack type housing, 1 unit (44.2 mm), depth = 245 mm

Power amplifier

	AK 205 N	AK 405 N
2 inputs switchable	0,25 - 3,2 V 20 kOhms balanced floating	
Output	100 / 70,7 / 50 V	100 / 70,7 / 50 V
Output power (IEC 268-3)	200 W	400 W
rated load impedance	50/25/12,5 Ohm	25/12,5/6,25 Ohm
Pilot tone plug in	PT 26 (opt.)	PT 26 (opt.)
Bass filter	200 Hz / -6dB / oct., switchable	
Cooling system	Convection	Fan
Mains power	230 V AC, 50/60 Hz	230 V AC, 50/60 Hz
Power consumption	about 440 VA	about 880 VA
Battery power	24 V DC	24 V DC
Rated battery current / idle current	16 / 0,35 A	34 / 0,5 A
19" rack type housing / depth	2 units / 335 mm	3 units / 325 mm

DLC 64 N - digital line control system

No. of monitored lines: 16, extendable with DLR 16N/DLR 32N, monitoring for impedance, short cut, cable break, ground fault. Message output: LCD-display and via KSM 500, configuration/service: by RS 232 port, expansion facility: up to 32 or 48 loud



KH(SAFE 500)

Features

Continuous failure monitoring

- Continuous microprocessor monitoring of the complete signal path and all safety affected components from the emergency microphone up to the end of the loudspeaker line in intervals of less than 100 seconds.
- Continuous monitoring of fire alarm microphone including its capsule and voice coil
- Continuous monitoring of loudspeaker lines for open and closed circuit faults. Rated value tolerance deviations are adjustable from 5% to 50%. Automatic adjustment to gradually altering rated values due to temperature changes, aging etc.
- Permanent active monitoring of up to 48 speaker lines. Automatic system configuration at start up
- Continuous monitoring of non active loudspeaker lines, too
- Continuous monitoring of all power amplifiers with automatic switching to standby amplifiers

Inaudible control

- The monitoring is completely inaudible without interruption of chime or programmed sound

Documentation

- Saving and printing monitoring error messages via RS 232 interface
- Optical error display showing the faulty component for easy determination of cause of malfunction

Selectable emergency calls

- Up to 2 emergency call microphones (Fire Department Microphones) with 3 selectable call zones each (16 speaker lines can be routed without any special tools to each zone) and all call
- Accepting reports from the fire alarm systems for automatic triggering emergency announcements. Intelligent control in case of multiple incoming messages.

- Non volatile memory of four different emergency announcements on monitored digital voice recorder with very high sound quality
- Automatic generation of a standardized alarm tone, chime or siren and triggering manually, centrally or decentralized.

Trouble free battery operation

- Automatic, non interrupted switching to battery operation in case of mains failure
- Maximum battery lifetime and safe emergency power management with emergency power manager system NT 24 (manufacturer AVB Blumberg, www.avb.de) offering extensive display-, surveillance-, charging- and control-functions
- Standby operation of the system provides for lower battery capacity and longer bypass time from mains power failure to alarm triggering
- Full sound pressure level for alarm announcements through full amplifier output power, also at battery operation

Versatile use

- Connection of any standard microphone system for paging announcements (manufacturer AVB Blumberg, www.avb.de). The system can be used as a regular PA-system for announcements, chime for breaks and audio programs
- Clock timer input for triggering chime or other signals

Economical and rational

- Economical project solutions because of modular design
- Economical wiring and assembly of system

Extension features

- Extension features to individual loudspeaker control DLE 64N monitoring every single loudspeaker without any additional wiring

KH(SAFE 500)

System Description

Sound systems for emergency purposes as specified in the EN 60 849 standard prescribing extensive control and monitoring of sound systems for emergency purposes can be set up economically with components of the

KH(SAFE 500)

system. The central unit is easily planned, quick and simple to mount and comfortable to wire.

ASS 503 - emergency microphone

Can be established for 3 loudspeaker lines and all call, with an interface for the monitoring functions, building up max. 3 call groups each consisting of up to 16 loud speaker lines.

Two emergency call microphones can be connected. The good looking emergency microphone is a desktop model, which also can be wall mounted (option). The high grade elektret condenser capsule on a slim goose neck is permanently monitored including the full signal path. A high level balanced audio output facilitates wiring.

PA microphone systems for paging

For conventional PA-program operation with paging and background music the system has a high practical value. PA paging microphone systems (we recommend systems of AVB-Blumberg/www.avb.de) can be connected easily to the ESM 504 priority module.

With the input modules (TTM 504 line input module, TEM 501 telephone adaptor module, SKM 501 master/EQ module etc.) various program source configurations can be realized. These signal paths are not monitored by the system.

ESM 504 - input/priority module

This module provides for the signal amplification, the mixing and the priority routing for regular and emergency microphones. When using the ASS 503 emergency microphone the ESM 504's first input has to be fitted with a SX 65 (balanced line) plug in amplifier.

In order to adjust the sound characteristics for best intelligibility separate controls for treble and bass are standard.

GAM 503 / A - alarm tone generator module

This module generates various alarm signals (two tones alternating, continued tone, pulsed tone, alarm tone according to DIN 33404, siren) which are introduced into the signal path with priority.

Triggering can be done at the central unit as well as at a remote control device.

GAM 503 / G - chime module

This module is equipped with a chime generator and used for playback of chime signals such as sign for breaks in schools, factories, retirement homes etc.

Maximum four well sounding chime tones can be called off as five different and distinctive signals.

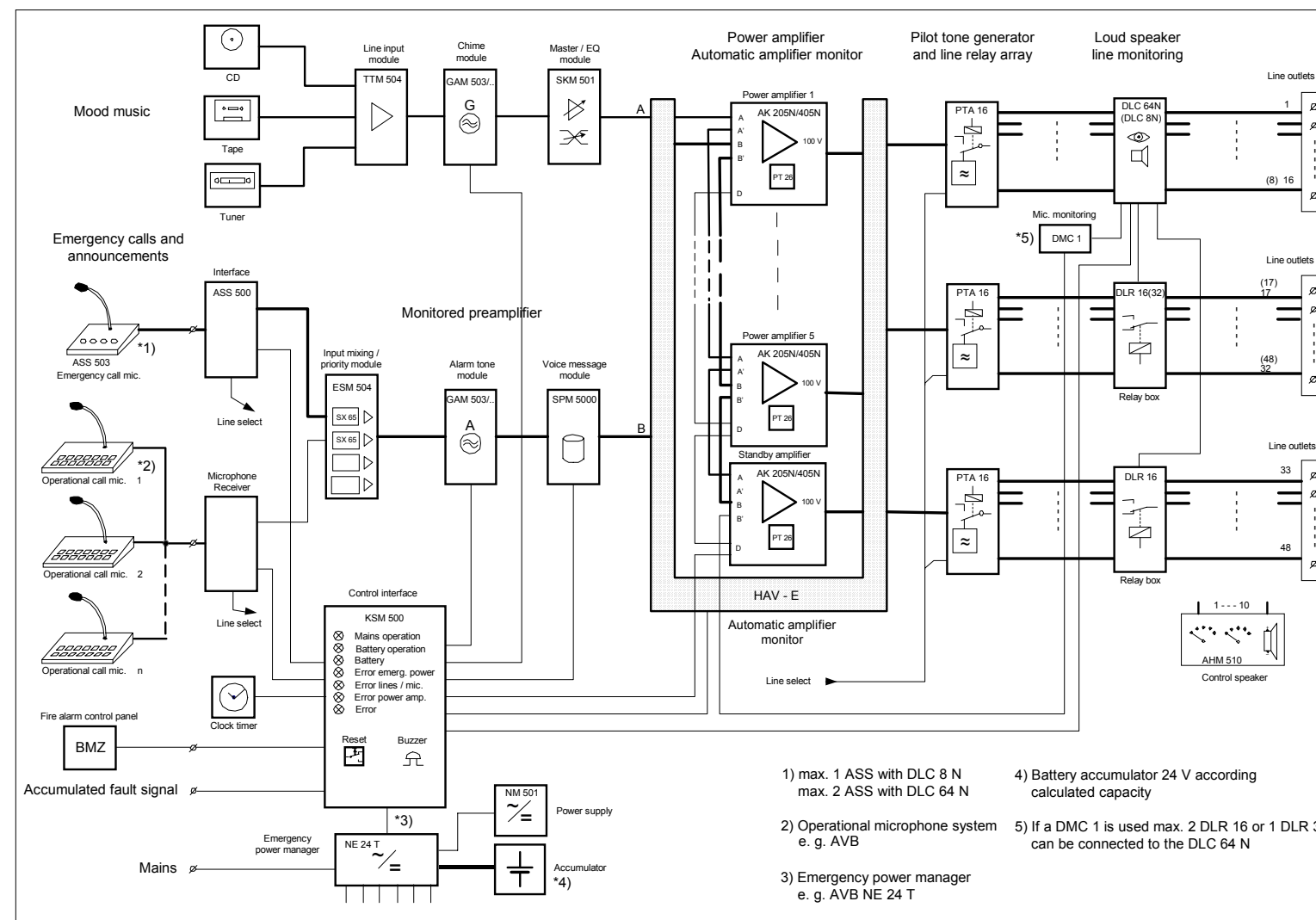

- 1) max. 1 ASS with DLC 8 N
max. 2 ASS with DLC 64 N
- 2) Operational microphone system
e. g. AVB
- 3) Emergency power manager
e. g. AVB NE 24 T
- 4) Battery accumulator 24 V according
calculated capacity
- 5) If a DMC 1 is used max. 2 DLR 16 or 1 DLR 32
can be connected to the DLC 64 N

KH(SAFE 500) Example of a monitored central unit according to EN 60849

The PT 26 pilot tone generator (optional) supports the amplifier failure monitoring system switching to a standby amplifier as specified by the standard. Today's latest and energy saving circuit design economizes battery power and provides for longer operational and bypass periods at lowest battery capacity.

HAV - E - automatic amplifier monitor

Up to six power amplifiers and one standby amplifier are monitored both in one program or multiple program operations. Failure of one amplifier causes the standby amplifier to be inserted automatically and an error signal is generated, showing which amplifier has failed.

PTA 16 - line relay unit with pilot tone generator

Contains a pilot tone generator and 16 loudspeaker line relays. It is also feeding the pilot tone into switched off loudspeaker lines.

DLC 8 N - digital line control system

For monitoring up to eight 100 V loudspeaker lines for impedance, short cut, cable breakage and ground fault. It controls without any interruptions of the sound transmission, permanently and inaudibly all active and non active (PTA 16) loudspeaker lines. Extension connector for microphone control monitoring via DMC 1. A very competitive solution for smaller systems, but without extension facility (see DLC 64N for more than 8 lines).

DLC 64 N - digital line control system

For monitoring up to 16 (32/48) 100 V loud-speaker lines for impedance, short cut, cable break and ground fault. It controls without any interruptions of the sound transmission, permanently and inaudibly all active and non active (PTA 16) loudspeaker lines. Extension connector for microphone control monitoring via DMC 1. Line extension facilities with DLR 16 N or DLR 32 N.

DLR 16 N - relay box

For extending the DLC 64 N from standard 16 to 32 or max. 48 loud-speaker lines.

DLR 32 N - relay box

For extending the DLC 64 N from standard 16 to 32 or max. 48 loud-speaker lines.

DMC 1 - digital microphone control module

Will be plugged onto the DLC 8 N or DLC 64 N, monitoring the ASS 503 emergency microphone controlling the signal complete path up to the power amplifiers input. Fulfills the EN 60849 standard.

KSM 500 - control and interface module

Manages the power / battery power supply as well as switching on and off all the components of the emergency sound system. It analyzes the alarm tone and chime sound requirements as well as the error messages of all components connected to the system. Generates the necessary commands, messages and control signals (electrical, optical and acoustic) according to the EN 60849 standard.

NM 501 - power supply module

Provides power supply for the DC operated KH(SAFE 500) components and modules.

NE 24 T - emergency power manager

Serves for monitoring constantly the mains power supply. Temperature controlled charging and checking of batteries as well as controlling 6 DC emergency power outputs. The microprocessor driven device is strictly designed to the rules of the EN 60849. Long battery life time is ensured in compliance with the accumulator manufacturers specifications. Manufactured by AVB-Blumberg, Germany, www.avb.de.