

EK 6042

使用说明

目录

便携式摄像机接收机 EK 6042	5
供货范围	5
产品总览	6
上侧	6
按键功能	7
前侧	7
下侧	8
LED 指示灯	8
显示屏	9
后面板适配器	11
调试	12
EK 6042 用于摄像机中	12
连接后面板适配器	13
连接充电电池组适配器	13
连接录音器或者混音器	14
连接耳机	14
操作	15
接通或关闭	15
调用标准显示屏、CH1 或 CH2 显示屏	15
使用操作菜单	15
执行同步 (Sync)	17
执行自动配置 (Auto)	18
进行频率扫描	19
切换场景	19
用网络浏览器进行配置	20
护理和维护	22
附件	22
技术参数	23
许可证	1
eCos	1
Display Font (Palm OS)	1
DHCP Server (dhcps)	1
The Creative Commons License	2
引脚分配	1

注册商标

- ARRI 是 Arnold & Richter Cine Technik GmbH & Co. Betriebs KG 的注册商标。
- Panasonic 是 Panasonic Corporation 的注册商标。
- Sony 是 Sony Corporation 的注册商标。
- UniSlot 是 Ikegami Tsushinki Co., Ltd. 的注册商标。
- SuperSlot™ 是 Sound Devices, LLC. 的注册商标。

便携式摄像机接收机 EK 6042

EK 6042 是一种小型双通道真分集接收机。它适用于带有 UniSlot/ SuperSlot™ 接口（例如 Panasonic、Ikegami、ARRI、Sound Devices）或 Sony 接口的专业摄像机或移动混音器，插入接收机插口即可使用。与性能卓越的 Sennheiser 口袋式发射机、接插式发射机或手握式发射机共同形成极为安全可靠且高品质的声音传输路径。

EK 6042 的突出特点有：

- 同时接收两台发射机
- 几乎兼容所有 Sennheiser 发射机和麦克风，例如
 - LR 模式的 Digital 9000 系列数字发射机
 - FM 模式的 5000、3000 和 2000 系列模拟发射机，并兼容压扩系统 HDX 或 HiDyn plus
- 可选模拟或数字音频输出
- 操作极为简单，原因如下
 - 快速简单的 One Touch Easy Setup
 - 通过显示屏菜单引导操作
 - 可以通过网络浏览器进行配置
- 针对带有 UniSlot/SuperSlot™（例如 Panasonic、Ikegami、ARRI、Sound Devices）和 Sony 接口的专业摄像机有适配器可用
- 可选摄像机供电、移动电源或 Sennheiser 充电电池组适配器 GA 6042 BA
- 通过真分集接收实现高运行安全性
- 附件丰富，适用于每种应用情况（参见“附件”，第 22 页）

供货范围

- 1 摄像机接收机 EK 6042
- 2 天线
 - 1 USB 线
 - 1 收纳盒
 - 1 使用说明书

关于电源、电缆和适配器等附件的信息参见第 22 页。

产品总览

上侧

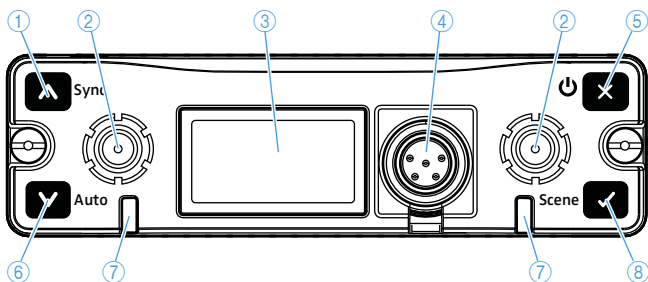

- ① 按键 

短按：在菜单中向上导航或切换到标准显示屏
 长按：参见“执行同步 (Sync)”，第 17 页
- ② SMA 插孔

用于可拆下的天线（分集支线 A 和 B）
- ③ 显示屏

详细说明参见第 9 页
- ④ Mini-XLR-5 插孔 (Top) AUX 1/2

次级音频输出端 AUX 1 和 AUX 2 的音频插孔（位于盖板下）
 只输出模拟音频信号
 与音频插孔 AUX 1/2 输出同样的音频信号
- ⑤ 按键 









短按：退出菜单项
 长按：参见“接通或关闭”，第 15 页
- ⑥ 按键 

短按：在菜单中向下导航或切换到标准显示屏
 长按：参见“执行同步 (Sync)”，第 17 页
- ⑦ LED CH1 和 CH2

接收通道 1 或 2 的 LED 状态指示灯
 详细说明参见第 8 页
- ⑧ 按键 

短按：确认选择
 长按：参见“切换场景”，第 19 页

按键功能

按键	功能
 短按	<ul style="list-style-type: none"> • 返回上一级操作菜单 • 退出菜单项，不应用任何输入内容
 长按	<ul style="list-style-type: none"> • 接通 EK 6042（参见第 15 页） • 关闭 EK 6042
 短按	<ul style="list-style-type: none"> • 从当前的标准显示屏、CH1 或 CH2 显示屏切换到操作菜单 • 调用所选的菜单项
 (Scene) 长按	<ul style="list-style-type: none"> • 调用保存的场景（参见第 20 页）
 短按	<ul style="list-style-type: none"> • 在标准显示屏、CH1 和 CH2 显示屏之间切换 • 切换到上一菜单项 • 增加设置的值
 (Sync) 长按	<ul style="list-style-type: none"> • 同步发射机与 EK 6042（参见第 17 页）
 短按	<ul style="list-style-type: none"> • 在标准显示屏、CH1 和 CH2 显示屏之间切换 • 切换到下一菜单项 • 减小设置的值
 (Auto) 长按	<ul style="list-style-type: none"> • 启动自动配置（参见第 18 页）

前侧

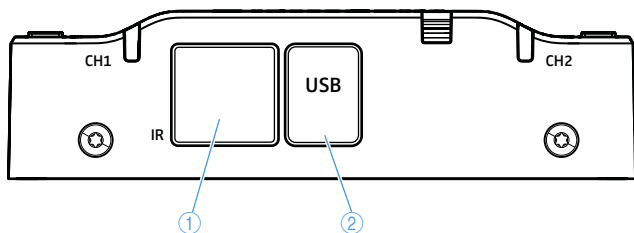

- ① 红外线接口 用于与发射机进行同步（参见第 17 页的 [Sync](#) 和第 18 页的 [Auto](#)）
- ② USB 接口 用于连接计算机，用网络浏览器进行配置（参见第 20 页）

下侧

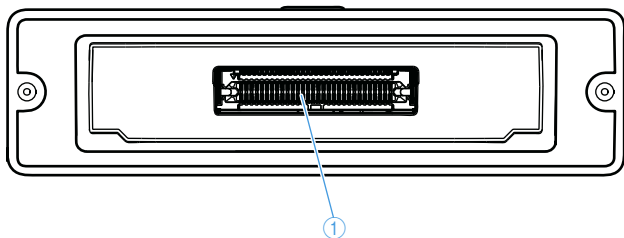

- ① 多针脚接口 用于连接附件

LED 指示灯

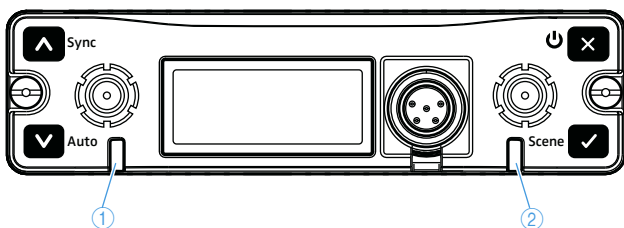

- ① LED CH1 接收通道 CH1 的 LED 状态指示灯
- ② LED CH2 接收通道 CH2 的 LED 状态指示灯

LED 指示灯	含义
不亮	接收通道关闭，例如，以节省充电电池的电量。显示屏上显示 “Inactive”。关于接收通道的打开 / 关闭参见 “ Channel Power ”，第 16 页。
绿色	接收通道打开并接收一台发射机。发射机和接收机充电电池电量充足。
黄色	显示屏上显示一条状态信息。
红色	接收通道不接收发射机。

显示屏

显示屏显示不同的状态信息以及操作菜单。关于以下显示屏的调用参见第 15 页。关于操作菜单参见第 15 页。

标准显示屏

接通后显示标准显示屏。

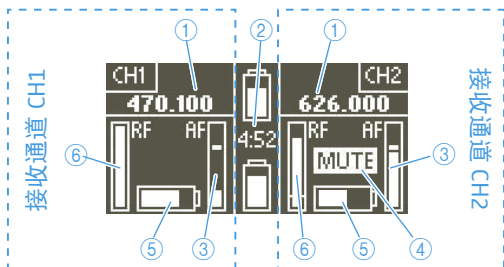

① 接收频率

② 电源的来源和状态：



使用充电电池组适配器 GA 6042 BA 时，显示所插入充电电池组 BA 61 的电量和剩余运行时间。

如果连接了外部电源，将显示一个插头图标。



如果 EK 6042 插在一台摄像机的接收器插口中工作，将显示一个摄像机图标。



如果 EK 6042 插在一个兼容的 SuperSlot™ 的接收机插口中，将显示该图标。

③ 具有 Peak Hold 功能的发射机的音频声压级

④ Mute 显示：EK 6042 由于接收信号不充足或受到干扰而将音频输出切换为静音模式，或者接收到的发射机已通过其静音开关 MUTE 切换为静音模式。

⑤ 接收到的发射机的充电电池电量

⑥ 接收通道接收到的接收信号强度

CH1 和 CH2 显示屏

数字接收

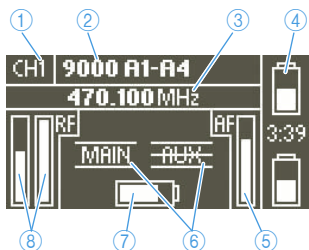

模拟接收

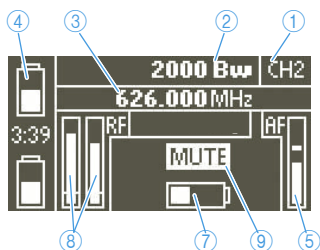

- ① 接收通道名称
- ② 接收到的发射机的名称
- ③ 接收频率
- ④ 电源的来源和状态（参见 ②，第 9 页）
- ⑤ 具有 Peak Hold 功能的发射机的音频声压级（偏差 / 调制）
- ⑥ 音频输出显示：
 - MAIN** 如果音频输出激活，则显示旁边所示的图标。
 - ALX** 如果借助 Command 功能禁用了音频输出，则显示划线的图标。
 - inactive** 如果在 **Channel Power** 菜单中关闭了接收通道，则显示“inactive”。
- ⑦ 接收到的发射机的充电电池电量
- ⑧ 两个分集支线的接收信号强度，同时显示静噪阈值
- ⑨ Mute 显示（参见 ④，第 9 页）

后面板适配器

后面板适配器 GA 6042 BP 可作为附件订购。如果想要在摄像机以外的设备上使用 EK 6042，则需要该适配器。

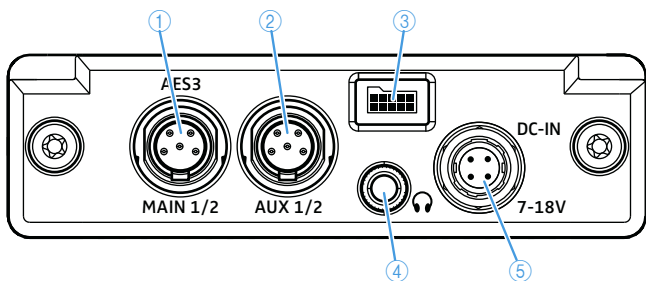

- | | |
|----------------------------------|---|
| ① Mini-XLR-5 插孔
AES3 MAIN 1/2 | 初级音频输出端的音频插孔
可以输出模拟或数字音频信号 |
| ② Mini-XLR-5 插孔
AUX 1/2 | 次级音频输出端 AUX 1 和 AUX 2 的音频插孔
只输出模拟音频信号
与音频插孔 (Top) AUX 1/2 输出同样的音频信号 |
| ③ 充电电池组插孔 | 用于连接充电电池组适配器 GA 6042 BA |
| ④ 3.5 mm TRS 插孔
PHONES | 用于连接耳机 |
| ⑤ 插孔 DC-IN | 用于连接外部电源 |

调试

EK 6042 用于摄像机中

您可以将 EK 6042 固定在摄像机的接收机插口中。若要安装在带有 UniSlot/SuperSlot™ 接口的摄像机（例如 Panasonic、Ikegami、ARRI、Sound Devices）中，需要用到 GA 6042-25 套装，若要安装在 Sony 摄像机中，需要用到 GA 6042-15 套装。每个套装都包括一个适配器转接板 ④ 和一个 D-Sub 适配器 ⑤。

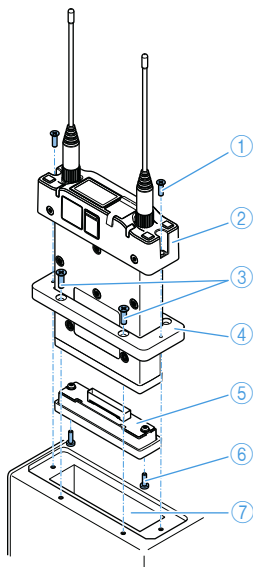

▶ 用四个随附的螺栓 ③ 将转接板拧在您摄像机的接收机插口 ⑦ 上。

▶ 小心地将 D-Sub 适配器插入 EK 6042 的多针脚接口 ② 中。用两个随附的螺栓 ⑥ 将 D-Sub 适配器拧紧在 EK 6042 上。

▶ 将 EK 6042 及安装的 D-Sub 适配器穿过转接板推入接收机插口中。

▶ 用两个随附的螺栓 ① 将 EK 6042 拧紧在摄像机上。

EK 6042 通过其多针脚接口与摄像机相连并通过摄像机的充电电池供电。

i 如果在带有 UniSlot/SuperSlot™ 接口的摄像机（例如 Panasonic、Ikegami、ARRI）中将 EK 6042 插入接收机插口，则两条接收通道的音频信号通过多针脚接口传输到摄像机。

如果在 Sony 摄像机中将 EK 6042 插入接收机插口，则摄像机可能只接受接收通道 CH1 的音频信号。为了使第二条接收通道 CH2 也传输到摄像机：

▶ 利用 Y 型转接线将 Mini-XLR-5 插孔 (Top) AUX 1/2 与 Sony 摄像机的第二个音频输入端相连。

连接后面板适配器

如需在摄像机之外的其他设备上（例如在移动混音器上）使用 EK 6042，需要用到后面板适配器 GA 6042 BP 以及一个外部电源。

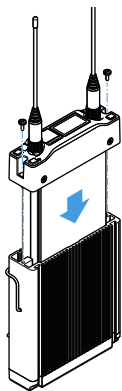

- ▶ 小心地将 EK 6042 完全推入后面板适配器中。
- ▶ 用两个随附的螺栓将 EK 6042 拧紧在后面板适配器上。
- ▶ 利用两根 Y 型转接线将初级和 - 如果需要 - 次级音频输出端连接到您的混音器上（参见第 14 页）。
- ▶ 利用 DC-IN 电缆 CA 6042 DC 将外部电源连接到插口 DC-IN 或安装充电电池组适配器 GA 6042 BA（见下文）。

i 可以取下后面板适配器的皮带夹。

连接充电电池组适配器

如需通过充电电池为 EK 6042 的运行供电，需要用到充电电池组适配器 GA 6042 BA、两个充电电池组 BA 61 和充电器 L 60:

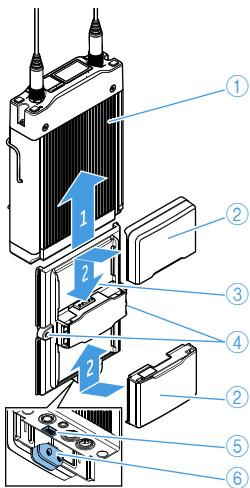

- ▶ 安装后面板适配器 ①（见上文）。
- ▶ 在后面板适配器正确的一侧推拢充电电池组适配器 ③，使后面板适配器的插头 ⑥ 连接到充电电池组的插孔 ⑤。
- ▶ 用两个随附的螺栓 ④ 将充电电池组适配器拧紧在后面板适配器上。
- ▶ 将两个充电电池组 BA 61 ② 插入充电电池组适配器，直至听到卡入声。

i 可以随时更换充电电池组——运行过程中亦可。第二个充电电池组在此期间负责供电。

连接录音器或者混音器

EK 6042 可以同时接收两台发射机。因此若要连接到录音器或混音器，至少需要一根 Y 型转接线。

- ▶ 在所需的音频输出端 (**MAIN 1/2** 和 / 或 **AUX 1/2**) 各连接一根 Y 型转接线。
- ▶ 在 **MAIN Format** 菜单项中设置所需的音频格式: **digital AES-3** 或 **analog**。

在初级音频输出端 **MAIN 1/2**，两条接收通道的音频信号可以以模拟或数字方式输出。在次级音频输出端 **AUX 1/2** 和 (**Top**) **AUX 1/2**，只能输出模拟音频信号。

连接耳机

危险

音量过高会损伤听力



耳机输出端可能产生高声压。较高音量或较长作用时间会使您的听力受损。

- ▶ 请设置适中的音量。
- ▶ 在切换发射机或更改频率前，请先降低音量级。

-
- ▶ 安装后面板适配器（参见第 13 页）。
 - ▶ 将耳机连接到后面板适配器的 3.5 mm TRS 插孔 **PHONES**。

操作

接通或关闭

如需接通 EK 6042:

- ▶ 长按 **[x]** 按键。

显示标准显示屏。耳机输出端的音量将自动设置为较低声压级。

如需关闭 EK 6042:

- ▶ 如果显示一个子菜单（参见第 16 页），多次按下 **[x]** 按键，直到显示标准显示屏、CH1 或 CH2 显示屏。
- ▶ 长按 **[x]** 按键。
播放一段动画。然后 EK 6042 关闭。

调用标准显示屏、CH1 或 CH2 显示屏

接通后显示标准显示屏 ①。

若要切换到 CH1 显示屏 ② 或 CH2 显示屏 ③:

- ▶ 按下 **[▲]** 按键或 **[▼]** 按键。

若要从操作菜单（参见第 16 页）切换回标准显示屏:

- ▶ 多次按下 **[x]** 按键，直到显示标准显示屏。

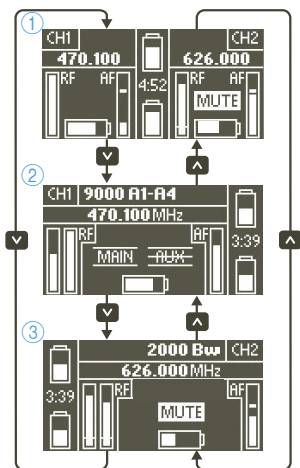

使用操作菜单

调用操作菜单

- ▶ 在显示标准显示屏、CH1 显示屏或 CH2 显示屏时，短按 **[✓]** 按键。
 - 如果从标准显示屏中调用操作菜单，将显示 **MAIN Format** 菜单项。

- 如果从 CH1 显示屏中调用操作菜单，将显示 **CH1 Settings** 菜单项。
- 如果从 CH2 显示屏中调用操作菜单，将显示 **CH2 Settings** 菜单项。

操作菜单总览

主菜单	子菜单	可行的设置
CH1 Settings CH2 Settings	Transmitter	Search via IR : 通过红外线接口识别发射机
		List : 从列表中选择发射机
	Frequency	Scan to next 根据 Squelch 设置自动查找合适的频率
		Tune : 手动设置频率
		License : 选择预设频率
	Sync	通过红外线接口将频率传输至发射机；参见第 17 页
	Pilot Squelch	inactive : 导频静噪禁用
		active : 导频静噪激活
		not supported : 发射机不支持导频音
	Squelch	模拟接收: 设置静噪阈值
		数字接收: inactive
	MAIN Out AUX Out	always ON : 音频输出端始终打开
		ON by command : 可以利用 Command 功能激活音频输出端
		MUTE by command : 可以利用 Command 功能将音频输出切换为静音模式
Channel Power	inactive : 音频信号在所有输出插孔处切换为静音模式，仅在耳机输出端激活	
	active : 音频信号在所有输出插孔处激活	
MAIN Format		digital AES-3 或 analog
Level MAIN 1		数字接收: digital
Level MAIN 2		模拟接收: 设置音频声压级
Level AUX 1		设置音频声压级
Level AUX 2		



主菜单	子菜单	可行的设置
Testtone		on 或 off
PHONES Volume		设置耳机音量
PHONES Listen to		将接收通道 CH1 或 CH2 或 CH1+CH2 切换到耳机输出端
Store Scene		将当前设置保存为场景
Network		更改接收机的 IP 地址
Info		显示固件版本和字时钟状态
License List		显示许可的频率
Spectrum Scan		进行频率扫描

执行同步 (Sync)

在菜单 **CH1 Settings** 或 **CH2 Settings** 中，必须确保子菜单 **Transmitter**、**Frequency** 和 **Squelch** 中的设置与发射机相匹配。

有两种启动同步的方法。

第一种方法：

- ▶ 长按  按键。
显示接收通道选项。
- ▶ 选择用于同步的 **CH1** 或 **CH2**，然后按下  按键启动同步。



第二种方法：

- ▶ 调用子菜单 **Sync** (**CH1 Settings** 或 **CH2 Settings** 中)，然后按下  按键启动同步。

选择了 **CH1 Settings** 或 **CH2 Settings** 就意味着选择了与发射机同步的接收通道。因此不会再要求选择接收通道。

启动同步后，会显示 **Hold to IR** 且红外线接口闪烁蓝色。



- ▶ 将已接通发射机的红外线接口（参见发射机使用说明书）置于 EK 6042 的红外线接口前面。

EK 6042 上设置的频率传输到发射机中。如果未将发射机切换为静音模式，传输成功后，相应接收通道的 LED 状态指示灯便会亮起绿灯。无线传输路径旋即准备就绪。如果传输失败，显示信息 **Failure**。

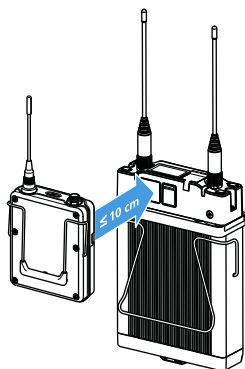

执行自动配置 (Auto)

无需进行手动设置。会自动获取子菜单

Transmitter、**Frequency** 和 **Squelch** 中相匹配的设置。

- ▶ 长按 按键。
显示接收通道选项。
- ▶ 选择 **CH1** 或 **CH2** 进行自动配置。
- ▶ 通过 按键启动自动配置。
显示 **Hold to IR**，红外线接口闪烁蓝色。

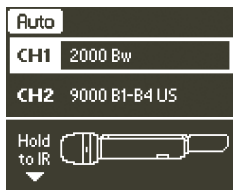

- ▶ 将已接通发射机的红外线接口（参见发射机使用说明书）置于 EK 6042 的红外线接口前面。

EK 6042 会识别发射机及其频率范围。之后红外线接口不再闪烁蓝色。

- ▶ 现在增大发射机与 EK 6042 之间的距离。视发射机型号而定，显示屏上可能会显示 **Increase transmitter distance**。在这种情况下，请使发射机与 EK 6042 再离远一点。

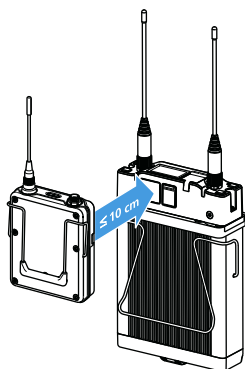

此时 EK 6042 会自动测定合适的频率以及环境中的噪音级，并在子菜单 **Transmitter**、**Frequency** 和 **Squelch** 中进行相应的设置。

接着会再次显示 **Hold to IR**，红外线接口再次闪烁蓝色。





- ▶ 再次将发射机的红外线接口置于EK 6042的红外线接口前面。所获取的频率将传输到发射机中。如果未将发射机切换为静音模式，传输成功后，相应接收通道的 LED 状态指示灯便会亮起绿灯。无线传输路径旋即准备就绪。如果传输失败，显示信息 **Failure**。

进行频率扫描

您可以进行频率扫描，以便获得现场当前频率情况的总览。频率扫描期间，两条接收通道的音频输出端将切换为静音模式。

-  为了设置接收频率，可以通过 **CH1 Settings** 和 **CH2 Settings** 菜单进入 **Frequency** 子菜单并使用其中的功能（参见第 16 页）。还可以执行自动设置（参见第 18 页）。

- ▶ 调用操作菜单（参见第 15 页），选择 **Spectrum Scan** 并确认警告。
频率扫描在 EK 6042 频率范围的中间开始，然后同时向较低和较高频率扫描。您可以随时通过  和  按键滚动扫描整个频率范围。
- ▶ 按下  按键返回操作菜单。

切换场景

如果在多次录制之间需要切换麦克风但是没有足够的配置时间，按照如下方法进行准备：

- ▶ 预先配置发射机和EK 6042。将所需的接收机配置保存为场景（见下文）。
最多可以保存 10 个场景。
- ▶ 通过调用所保存的场景，快速便捷地切换到需要的场景（参见第 20 页）。

保存场景

- ▶ 根据需要设置所有参数并同步相应的发射机。

- ▶ 调用操作菜单（参见第 15 页）并选择 **Store Scene**。
出现场景选项。



- ▶ 选择场景编号（**#1** 至 **#10**）。
配置将保存在所选的场景编号下。同时将覆盖早前的场景。可以在一个网络浏览器中查看和删除所有场景的配置（参见第 20 页）。

调用场景

有两种调用场景的方法。

第一种方法：

- ▶ 长按 按键。
出现场景选项。将显示预设频率、发射机名称和同步发射机的频段。
- ▶ 通过 或 按键选择所需的场景编号并通过 按键确认。
预设的配置立即生效。



第二种方法（快速选择）：

- ▶ 按住 按键并同时按下 或 按键，以导航至所需的场景编号。
- ▶ 松开两个按键。
最后一次选择的场景生效并显示标准显示屏。

用网络浏览器进行配置

可以将 EK 6042 直接连接到 Windows-PC 或 Mac 并用网络浏览器进行配置。

- ▶ 如果将 EK 6042 连接到 Windows-PC，则无需安装驱动器。
- ▶ 如果您使用 Mac，连接 EK 6042 之前，需要安装一个 RNDIS 驱动器。可在互联网免费下载用于 Mac 的 RNDIS 驱动器。



如果想要在您的计算机上同时连接多个 EK 6042，必须首先通过 **Network** 菜单项为接收机分配不同的 IP 地址。

- ▶ 利用 USB 线将 EK 6042 与您的计算机相连。
EK 6042 自动打开。首次连接到 Windows 计算机时会安装识别 EK 6042 所需的驱动器，这可能要持续几分钟。
然后 EK 6042 显示屏上会出现一个 URL。

- ▶ 将该 URL 输入网络浏览器的地址栏中。
网络浏览器中将出现下列菜单。

License List

在 **License List** 菜单中最多可以指定 100 个可自由选择的频率，在自动搜索可用频率时将优先选择这些频率。

Band List

在 **Band List** 菜单中最多可以指定 25 个可自由选择的频段，在自动搜索可用频率时将优先选择这些频段。

如果频率已添加到了 **License List** 菜单中（见上文），则该频率具有更高的优先级。

Transmitter Profiles

Transmitter Profiles 菜单包含预设的与 EK 6042 兼容的发射机配置文件。这些文件可以通过 **Default Profiles** 菜单项查看。

通过 **Custom Profiles** 菜单项也可以新建并编辑用户自定义的发射机配置文件 (**Add profile**) 或通过红外线接口确定发射机 (**Detect over IR**)。兼容但未知的发射机将自动添加到这里。

Scenes

在 **Scenes** 菜单中可以点击您所保存的场景（参见第 19 页）以查看所有设置。

点击 **X** 可以删除设置。

Maintenance

通过该配置菜单还可以：

- 重置 EK 6042
- 导入 / 导出配置
- 执行固件更新

护理和维护

注意

液体会损坏产品的电子线路。

如果液体流入产品外壳，则会导致电路短路。

▶ 设备不得与任何液体发生接触。

▶ 禁止使用溶剂或者清洁剂。

▶ 请定期用微湿的软布清洁 EK 6042 及附件。

附件

产品	产品编号	说明
EK 6042 A	506210	便携式摄像机接收机
GA 6042-15	506213	Sony 15 针 D-Sub 适配器
GA 6042-25	506212	UniSlot/SuperSlot™ 25 针 D-Sub 适配器
GA 6042 BP	506214	后面板适配器
GA 6042 BA	506215	充电电池组适配器
CA 6042 XLR	506216	Y 型转接线 (Mini-XLR 转 2 个 XLR)
CA 6042 DC	506217	DC-IN 电缆
BA 61	504703	充电电池组
L 60	504704	用于 BA 61 充电的充电器

技术参数

高频特性

接收机工作原理	超外差及数字解调
接收通道	2
接收兼容性	数字调制: Digital 9000 LR 模式 宽频 FM: HiDyn Plus、HDX
频率范围	470 至 654 MHz
开关带宽	184 MHz
调节步长	≥ 5 kHz
接收分集	真分集 (2 x 2 接收机)
灵敏度	“LR 模式”: -90 dBm “FM 模式”: $-94\text{ dBm @ }52\text{ dB Audio SNR}$
天线输入端	2 个 SMA 插孔 (50 Ω)
天线类型	2 个 UHF 宽频天线
相邻频道选择	典型值 70 dB (通道间距 ≥ 400 kHz)

音频特性

音频频率特性	20 Hz 至 20 kHz (+/-1.5 dB)
动态	> 108 dB(A)
非线性谐波失真系数	“LR 模式”: <math>< 0.03\%</math> (当频率为 1 kHz 时) “FM 模式”: <math>< 0.5\%</math> (当频率为 1 kHz 时)
时延	“LR 模式”: 3.0 ms (AES3) “FM 模式”: 1.5 ms (AES3)
音频输出端	5 针 Mini-XLR (公头), 对称
MAIN 1/2	数字: 0 dBFs、AES3、48 kHz、24 bit 模拟: -22 dBu 至 +8 dBu (可调)
(Top) AUX 1/2	模拟: -22 dBu 至 +8 dBu (可调)

其他特性

尺寸（高 x 宽 x 深）	约 107 x 90 x 26 mm（不包括天线）
重量	约 340 g
配置接口	微型 USB 插孔，B 型
多针脚接口	用于 GA 6042 适配器的 60 针插头

使用后面板适配器 GA 6042 BP

功率消耗	12 V 时典型值 3 W（7 至 18 V）
输入电压	4 针 DC-IN 插孔， 典型值 12 V（7 至 18 V）
耳机输出端	3.5 mm TRS 接口 2 x 25 mW，32 Ω
尺寸（高 x 宽 x 深）	约 135 x 90 x 26 mm
音频输出端	5 针 Mini-XLR（公头），对称
MAIN 1/2 数字：	0 dBFs、AES3、48 kHz、24 bit
模拟：	-22 dBu 至 +8 dBu（可调）
(Top) AUX 1/2 模拟：	-22 dBu 至 +8 dBu（可调）

使用充电电池组适配器 GA 6042 BA

（需要使用 GA 6042 BP）

兼容的充电电池组	Sennheiser BA 61
工作时间	> 4 小时 （用 2 块充电电池组 BA 61）
尺寸（高 x 宽 x 深）	约 135 x 90 x 44 mm

使用 D-Sub 适配器

D-Sub 适配器	GA 6042-15	GA 6042-25
摄像机接口	D-Sub-15（公头） （Sony）	D-Sub-25（公头） （UniSlot/SuperSlot™）
尺寸（高 x 宽 x 深）	约 135 x 90 x 26 mm	

工作条件

环境温度	-10°C 至 +55°C
相对空气湿度	40°C 时最高 90%（无冷凝）
滴水 and 溅水防护	不能有水滴和水溅落在设备上 (IP2X)。

存放和运输条件

环境温度	-25°C 至 +70°C
相对空气湿度	40°C 时最高 90%
滴水 and 溅水防护	不能有水滴和水溅落在设备上 (IP2X)。
抗震荡能力	符合 IEC 68 或 EN 60068, T2-27

Licenses

This product includes software code developed by third parties. Please find below a list of all used third party files.

eCos

Copyright (c) 2014, eCosCentric Ltd. All rights reserved.

Redistribution and use in source and binary forms, with or without modification, are permitted provided that the following conditions are met:

- Redistributions of source code must retain the above copyright notice, this list of conditions and the following disclaimer.
- Redistributions in binary form must reproduce the above copyright notice, this list of conditions and the following disclaimer in the documentation and/or other materials provided with the distribution.
- Neither the name of the copyright holder nor the names of its contributors may be used to endorse or promote products derived from this software without specific prior written permission.

THIS SOFTWARE IS PROVIDED BY THE COPYRIGHT HOLDERS AND CONTRIBUTORS "AS IS" AND ANY EXPRESS OR IMPLIED WARRANTIES, INCLUDING, BUT NOT LIMITED TO, THE IMPLIED WARRANTIES OF MERCHANTABILITY AND FITNESS FOR A PARTICULAR PURPOSE ARE DISCLAIMED. IN NO EVENT SHALL THE COPYRIGHT HOLDER OR CONTRIBUTORS BE LIABLE FOR ANY DIRECT, INDIRECT, INCIDENTAL, SPECIAL, EXEMPLARY, OR CONSEQUENTIAL DAMAGES (INCLUDING, BUT NOT LIMITED TO, PROCUREMENT OF SUBSTITUTE GOODS OR SERVICES; LOSS OF USE, DATA, OR PROFITS; OR BUSINESS INTERRUPTION) HOWEVER CAUSED AND ON ANY THEORY OF LIABILITY, WHETHER IN CONTRACT, STRICT LIABILITY, OR TORT (INCLUDING NEGLIGENCE OR OTHERWISE) ARISING IN ANY WAY OUT OF THE USE OF THIS SOFTWARE, EVEN IF ADVISED OF THE POSSIBILITY OF SUCH DAMAGE.

Display Font (Palm OS)

Copyright (c) 2012 DamienG

Used under the terms of the Creative Commons License.

http://fontstruct.com/fontstructions/show/palm_os

DHCP Server (dhcps)

Copyright (c) 2010, Valhalla Wireless, Todd Elliott

<http://valhalla-wireless.com/>All rights reserved.

Redistribution and use in source and binary forms, with or without modification, are permitted provided that the following conditions are met:

- Redistributions of source code must retain the above copyright notice, this list of conditions and the following disclaimer.
- Redistributions in binary form must reproduce the above copyright notice, this list of conditions and the following disclaimer in the documentation and/or other materials provided with the distribution.

- Neither the name of the Valhalla Wireless nor the names of its contributors may be used to endorse or promote products derived from this software without specific prior written permission.

THIS SOFTWARE IS PROVIDED BY THE COPYRIGHT HOLDERS AND CONTRIBUTORS "AS IS" AND ANY EXPRESS OR IMPLIED WARRANTIES, INCLUDING, BUT NOT LIMITED TO, THE IMPLIED WARRANTIES OF MERCHANTABILITY AND FITNESS FOR A PARTICULAR PURPOSE ARE DISCLAIMED. IN NO EVENT SHALL Valhalla Wireless BE LIABLE FOR ANY DIRECT, INDIRECT, INCIDENTAL, SPECIAL, EXEMPLARY, OR CONSEQUENTIAL DAMAGES (INCLUDING, BUT NOT LIMITED TO, PROCUREMENT OF SUBSTITUTE GOODS OR SERVICES; LOSS OF USE, DATA, OR PROFITS; OR BUSINESS INTERRUPTION) HOWEVER CAUSED AND ON ANY THEORY OF LIABILITY, WHETHER IN CONTRACT, STRICT LIABILITY, OR TORT (INCLUDING NEGLIGENCE OR OTHERWISE) ARISING IN ANY WAY OUT OF THE USE OF THIS SOFTWARE, EVEN IF ADVISED OF THE POSSIBILITY OF SUCH DAMAGE.

The Creative Commons License

THE WORK (AS DEFINED BELOW) IS PROVIDED UNDER THE TERMS OF THIS CREATIVE COMMONS PUBLIC LICENSE ("CCPL" OR "LICENSE"). THE WORK IS PROTECTED BY COPYRIGHT AND/OR OTHER APPLICABLE LAW. ANY USE OF THE WORK OTHER THAN AS AUTHORIZED UNDER THIS LICENSE OR COPYRIGHT LAW IS PROHIBITED.

BY EXERCISING ANY RIGHTS TO THE WORK PROVIDED HERE, YOU ACCEPT AND AGREE TO BE BOUND BY THE TERMS OF THIS LICENSE. TO THE EXTENT THIS LICENSE MAY BE CONSIDERED TO BE A CONTRACT, THE LICENSOR GRANTS YOU THE RIGHTS CONTAINED HERE IN CONSIDERATION OF YOUR ACCEPTANCE OF SUCH TERMS AND CONDITIONS.

1. Definitions

- a. **"Adaptation"** means a work based upon the Work, or upon the Work and other pre-existing works, such as a translation, adaptation, derivative work, arrangement of music or other alterations of a literary or artistic work, or phonogram or performance and includes cinematographic adaptations or any other form in which the Work may be recast, transformed, or adapted including in any form recognizably derived from the original, except that a work that constitutes a Collection will not be considered an Adaptation for the purpose of this License. For the avoidance of doubt, where the Work is a musical work, performance or phonogram, the synchronization of the Work in timed-relation with a moving image ("synching") will be considered an Adaptation for the purpose of this License.
- b. **"Collection"** means a collection of literary or artistic works, such as encyclopedias and anthologies, or performances, phonograms or broadcasts, or other works or subject matter other than works listed in Section 1(f) below, which, by reason of the selection and arrangement of their contents, constitute intellectual creations, in which the Work is included in its entirety in unmodified form along with one or more other contributions, each constituting separate and independent works in themselves, which together are assembled into a collective whole. A work that constitutes a Collection will not be consid-

ered an Adaptation (as defined below) for the purposes of this License.

- c. **“Creative Commons Compatible License”** means a license that is listed at <https://creativecommons.org/compatiblelicenses> that has been approved by Creative Commons as being essentially equivalent to this License, including, at a minimum, because that license: (i) contains terms that have the same purpose, meaning and effect as the License Elements of this License; and, (ii) explicitly permits the relicensing of adaptations of works made available under that license under this License or a Creative Commons jurisdiction license with the same License Elements as this License.
- d. **“Distribute”** means to make available to the public the original and copies of the Work or Adaptation, as appropriate, through sale or other transfer of ownership.
- e. **“License Elements”** means the following high-level license attributes as selected by Licensor and indicated in the title of this License: Attribution, ShareAlike.
- f. **“Licensor”** means the individual, individuals, entity or entities that offer(s) the Work under the terms of this License.
- g. **“Original Author”** means, in the case of a literary or artistic work, the individual, individuals, entity or entities who created the Work or if no individual or entity can be identified, the publisher; and in addition (i) in the case of a performance the actors, singers, musicians, dancers, and other persons who act, sing, deliver, declaim, play in, interpret or otherwise perform literary or artistic works or expressions of folklore; (ii) in the case of a phonogram the producer being the person or legal entity who first fixes the sounds of a performance or other sounds; and, (iii) in the case of broadcasts, the organization that transmits the broadcast.
- h. **“Work”** means the literary and/or artistic work offered under the terms of this License including without limitation any production in the literary, scientific and artistic domain, whatever may be the mode or form of its expression including digital form, such as a book, pamphlet and other writing; a lecture, address, sermon or other work of the same nature; a dramatic or dramatico-musical work; a choreographic work or entertainment in dumb show; a musical composition with or without words; a cinematographic work to which are assimilated works expressed by a process analogous to cinematography; a work of drawing, painting, architecture, sculpture, engraving or lithography; a photographic work to which are assimilated works expressed by a process analogous to photography; a work of applied art; an illustration, map, plan, sketch or three-dimensional work relative to geography, topography, architecture or science; a performance; a broadcast; a phonogram; a compilation of data to the extent it is protected as a copyrightable work; or a work performed by a variety or circus performer to the extent it is not otherwise considered a literary or artistic work.
- i. **“You”** means an individual or entity exercising rights under this License who has not previously violated the terms of this License with respect to the Work, or who has received express permission from

the Licensor to exercise rights under this License despite a previous violation.

- j. **“Publicly Perform”** means to perform public recitations of the Work and to communicate to the public those public recitations, by any means or process, including by wire or wireless means or public digital performances; to make available to the public Works in such a way that members of the public may access these Works from a place and at a place individually chosen by them; to perform the Work to the public by any means or process and the communication to the public of the performances of the Work, including by public digital performance; to broadcast and rebroadcast the Work by any means including signs, sounds or images.
- k. **“Reproduce”** means to make copies of the Work by any means including without limitation by sound or visual recordings and the right of fixation and reproducing fixations of the Work, including storage of a protected performance or phonogram in digital form or other electronic medium.

2. Fair Dealing Rights. Nothing in this License is intended to reduce, limit, or restrict any uses free from copyright or rights arising from limitations or exceptions that are provided for in connection with the copyright protection under copyright law or other applicable laws.

3. License Grant. Subject to the terms and conditions of this License, Licensor hereby grants You a worldwide, royalty-free, non-exclusive, perpetual (for the duration of the applicable copyright) license to exercise the rights in the Work as stated below:

- a. to Reproduce the Work, to incorporate the Work into one or more Collections, and to Reproduce the Work as incorporated in the Collections;
- b. to create and Reproduce Adaptations provided that any such Adaptation, including any translation in any medium, takes reasonable steps to clearly label, demarcate or otherwise identify that changes were made to the original Work. For example, a translation could be marked “The original work was translated from English to Spanish.” or a modification could indicate “The original work has been modified.”;
- c. to Distribute and Publicly Perform the Work including as incorporated in Collections; and,
- d. to Distribute and Publicly Perform Adaptations.
- e. For the avoidance of doubt:
 - i. **Non-waivable Compulsory License Schemes.** In those jurisdictions in which the right to collect royalties through any statutory or compulsory licensing scheme cannot be waived, the Licensor reserves the exclusive right to collect such royalties for any exercise by You of the rights granted under this License;
 - ii. **Waivable Compulsory License Schemes.** In those jurisdictions in which the right to collect royalties through any statutory or compulsory licensing scheme can be waived, the Licensor waives the exclusive right to collect such royalties for any exercise by You of the rights granted under this License; and,

- iii. Voluntary License Schemes. The Licensor waives the right to collect royalties, whether individually or, in the event that the Licensor is a member of a collecting society that administers voluntary licensing schemes, via that society, from any exercise by You of the rights granted under this License.

The above rights may be exercised in all media and formats whether now known or hereafter devised. The above rights include the right to make such modifications as are technically necessary to exercise the rights in other media and formats. Subject to Section 8(f), all rights not expressly granted by Licensor are hereby reserved.

4. Restrictions. The license granted in Section 3 above is expressly made subject to and limited by the following restrictions:

- a. You may Distribute or Publicly Perform the Work only under the terms of this License. You must include a copy of, or the Uniform Resource Identifier (URI) for, this License with every copy of the Work You Distribute or Publicly Perform. You may not offer or impose any terms on the Work that restrict the terms of this License or the ability of the recipient of the Work to exercise the rights granted to that recipient under the terms of the License. You may not sublicense the Work. You must keep intact all notices that refer to this License and to the disclaimer of warranties with every copy of the Work You Distribute or Publicly Perform. When You Distribute or Publicly Perform the Work, You may not impose any effective technological measures on the Work that restrict the ability of a recipient of the Work from You to exercise the rights granted to that recipient under the terms of the License. This Section 4(a) applies to the Work as incorporated in a Collection, but this does not require the Collection apart from the Work itself to be made subject to the terms of this License. If You create a Collection, upon notice from any Licensor You must, to the extent practicable, remove from the Collection any credit as required by Section 4(c), as requested. If You create an Adaptation, upon notice from any Licensor You must, to the extent practicable, remove from the Adaptation any credit as required by Section 4(c), as requested.
- b. You may Distribute or Publicly Perform an Adaptation only under the terms of: (i) this License; (ii) a later version of this License with the same License Elements as this License; (iii) a Creative Commons jurisdiction license (either this or a later license version) that contains the same License Elements as this License (e.g., Attribution-ShareAlike 3.0 US)); (iv) a Creative Commons Compatible License. If you license the Adaptation under one of the licenses mentioned in (iv), you must comply with the terms of that license. If you license the Adaptation under the terms of any of the licenses mentioned in (i), (ii) or (iii) (the "Applicable License"), you must comply with the terms of the Applicable License generally and the following provisions: (I) You must include a copy of, or the URI for, the Applicable License with every copy of each Adaptation You Distribute or Publicly Perform; (II) You may not offer or impose any terms on the Adaptation that restrict the terms of the Applicable License or the ability of the recipient of the Adaptation to exercise the rights granted to that

recipient under the terms of the Applicable License; (III) You must keep intact all notices that refer to the Applicable License and to the disclaimer of warranties with every copy of the Work as included in the Adaptation You Distribute or Publicly Perform; (IV) when You Distribute or Publicly Perform the Adaptation, You may not impose any effective technological measures on the Adaptation that restrict the ability of a recipient of the Adaptation from You to exercise the rights granted to that recipient under the terms of the Applicable License. This Section 4(b) applies to the Adaptation as incorporated in a Collection, but this does not require the Collection apart from the Adaptation itself to be made subject to the terms of the Applicable License.

- c. If You Distribute, or Publicly Perform the Work or any Adaptations or Collections, You must, unless a request has been made pursuant to Section 4(a), keep intact all copyright notices for the Work and provide, reasonable to the medium or means You are utilizing: (i) the name of the Original Author (or pseudonym, if applicable) if supplied, and/or if the Original Author and/or Licensor designate another party or parties (e.g., a sponsor institute, publishing entity, journal) for attribution (“Attribution Parties”) in Licensor’s copyright notice, terms of service or by other reasonable means, the name of such party or parties; (ii) the title of the Work if supplied; (iii) to the extent reasonably practicable, the URI, if any, that Licensor specifies to be associated with the Work, unless such URI does not refer to the copyright notice or licensing information for the Work; and (iv) , consistent with Section 3(b), in the case of an Adaptation, a credit identifying the use of the Work in the Adaptation (e.g., “French translation of the Work by Original Author”, or “Screenplay based on original Work by Original Author”). The credit required by this Section 4(c) may be implemented in any reasonable manner; provided, however, that in the case of a Adaptation or Collection, at a minimum such credit will appear, if a credit for all contributing authors of the Adaptation or Collection appears, then as part of these credits and in a manner at least as prominent as the credits for the other contributing authors. For the avoidance of doubt, You may only use the credit required by this Section for the purpose of attribution in the manner set out above and, by exercising Your rights under this License, You may not implicitly or explicitly assert or imply any connection with, sponsorship or endorsement by the Original Author, Licensor and/or Attribution Parties, as appropriate, of You or Your use of the Work, without the separate, express prior written permission of the Original Author, Licensor and/or Attribution Parties.
- d. Except as otherwise agreed in writing by the Licensor or as may be otherwise permitted by applicable law, if You Reproduce, Distribute or Publicly Perform the Work either by itself or as part of any Adaptations or Collections, You must not distort, mutilate, modify or take other derogatory action in relation to the Work which would be prejudicial to the Original Author’s honor or reputation. Licensor agrees that in those jurisdictions (e.g. Japan), in which any exercise of the right granted in Section 3(b) of this License (the right to make Adaptations) would be deemed to be a distortion, mutilation, modifica-

tion or other derogatory action prejudicial to the Original Author's honor and reputation, the Licensor will waive or not assert, as appropriate, this Section, to the fullest extent permitted by the applicable national law, to enable You to reasonably exercise Your right under Section 3(b) of this License (right to make Adaptations) but not otherwise.

5. Representations, Warranties and Disclaimer. UNLESS OTHERWISE MUTUALLY AGREED TO BY THE PARTIES IN WRITING, LICENSOR OFFERS THE WORK AS-IS AND MAKES NO REPRESENTATIONS OR WARRANTIES OF ANY KIND CONCERNING THE WORK, EXPRESS, IMPLIED, STATUTORY OR OTHERWISE, INCLUDING, WITHOUT LIMITATION, WARRANTIES OF TITLE, MERCHANTABILITY, FITNESS FOR A PARTICULAR PURPOSE, NONINFRINGEMENT, OR THE ABSENCE OF LATENT OR OTHER DEFECTS, ACCURACY, OR THE PRESENCE OF ABSENCE OF ERRORS, WHETHER OR NOT DISCOVERABLE. SOME JURISDICTIONS DO NOT ALLOW THE EXCLUSION OF IMPLIED WARRANTIES, SO SUCH EXCLUSION MAY NOT APPLY TO YOU.

6. Limitation on Liability. EXCEPT TO THE EXTENT REQUIRED BY APPLICABLE LAW, IN NO EVENT WILL LICENSOR BE LIABLE TO YOU ON ANY LEGAL THEORY FOR ANY SPECIAL, INCIDENTAL, CONSEQUENTIAL, PUNITIVE OR EXEMPLARY DAMAGES ARISING OUT OF THIS LICENSE OR THE USE OF THE WORK, EVEN IF LICENSOR HAS BEEN ADVISED OF THE POSSIBILITY OF SUCH DAMAGES.

7. Termination

- a. This License and the rights granted hereunder will terminate automatically upon any breach by You of the terms of this License. Individuals or entities who have received Adaptations or Collections from You under this License, however, will not have their licenses terminated provided such individuals or entities remain in full compliance with those licenses. Sections 1, 2, 5, 6, 7, and 8 will survive any termination of this License.
- b. Subject to the above terms and conditions, the license granted here is perpetual (for the duration of the applicable copyright in the Work). Notwithstanding the above, Licensor reserves the right to release the Work under different license terms or to stop distributing the Work at any time; provided, however that any such election will not serve to withdraw this License (or any other license that has been, or is required to be, granted under the terms of this License), and this License will continue in full force and effect unless terminated as stated above.

8. Miscellaneous

- a. Each time You Distribute or Publicly Perform the Work or a Collection, the Licensor offers to the recipient a license to the Work on the same terms and conditions as the license granted to You under this License.
- b. Each time You Distribute or Publicly Perform an Adaptation, Licensor offers to the recipient a license to the original Work on the same terms and conditions as the license granted to You under this License.

- c. If any provision of this License is invalid or unenforceable under applicable law, it shall not affect the validity or enforceability of the remainder of the terms of this License, and without further action by the parties to this agreement, such provision shall be reformed to the minimum extent necessary to make such provision valid and enforceable.
- d. No term or provision of this License shall be deemed waived and no breach consented to unless such waiver or consent shall be in writing and signed by the party to be charged with such waiver or consent.
- e. This License constitutes the entire agreement between the parties with respect to the Work licensed here. There are no understandings, agreements or representations with respect to the Work not specified here. Licensor shall not be bound by any additional provisions that may appear in any communication from You. This License may not be modified without the mutual written agreement of the Licensor and You.
- f. The rights granted under, and the subject matter referenced, in this License were drafted utilizing the terminology of the Berne Convention for the Protection of Literary and Artistic Works (as amended on September 28, 1979), the Rome Convention of 1961, the WIPO Copyright Treaty of 1996, the WIPO Performances and Phonograms Treaty of 1996 and the Universal Copyright Convention (as revised on July 24, 1971). These rights and subject matter take effect in the relevant jurisdiction in which the License terms are sought to be enforced according to the corresponding provisions of the implementation of those treaty provisions in the applicable national law. If the standard suite of rights granted under applicable copyright law includes additional rights not granted under this License, such additional rights are deemed to be included in the License; this License is not intended to restrict the license of any rights under applicable law.

Pin assignment

5-Pin-Mini-XLR (Male) AES3 MAIN 1/2, AUX 1/2, (Top) AUX

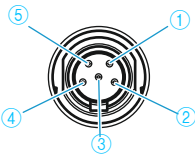

- ① GND
- ② CH 1 (+)
- ③ CH 1 (-)
- ④ CH 2 (+)
- ⑤ CH 2 (-)

DC-IN

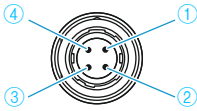

- ① GND
- ② -
- ③ -
- ④ Power

CA 6042 XLR Cable

3-Pin-XLR (Female) MAIN 2/AUX 2	5-Pin-Mini-XLR (Female)	3-Pin-XLR (Female) MAIN 1/AUX 1
<p>① GND</p>	<p>① GND</p>	<p>① GND</p>
	<p>② + (black) ③ - (green)</p>	<p>② + (black) ③ - (green)</p>
<p>④ + (white) ⑤ - (red)</p>	<p>④ + (white) ⑤ - (red)</p>	

D-Sub-15

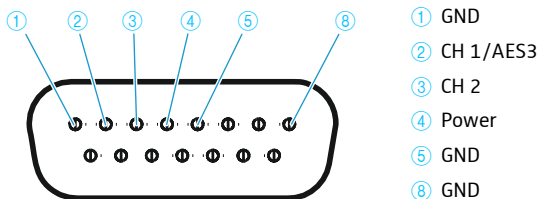

D-Sub-25

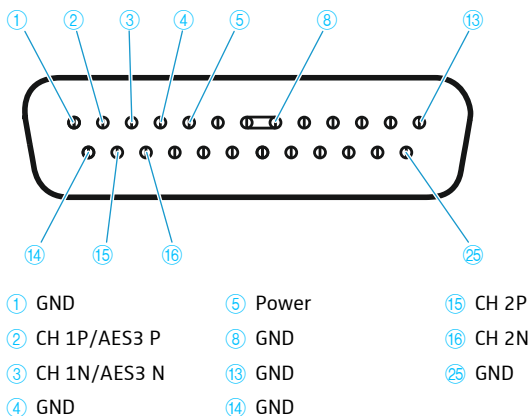

Unbelegte Pins dürfen nicht mit einem Signal belegt werden.

Unassigned pins must not be wired.

Les broches non assignées ne doivent pas être connectées.

I pin liberi non possono essere occupati da un segnale.

Los pines que no estén ocupados no se deben ocupar con una señal.

Os pinos sem ocupação não podem ser ocupados com um sinal.

Niet bezette pins mogen niet op een signaal worden aangesloten.

На неиспользуемые выводы не должны подаваться сигналы.

空闲的针脚不得被分配信号。



Sennheiser electronic GmbH & Co. KG

Am Labor 1, 30900 Wedemark, Germany

www.sennheiser.com

Publ. 06/19, 560088/A05